

REVISIONS			
REV	DESCRIPTION	DATE	APPROVED
--	--	--	--

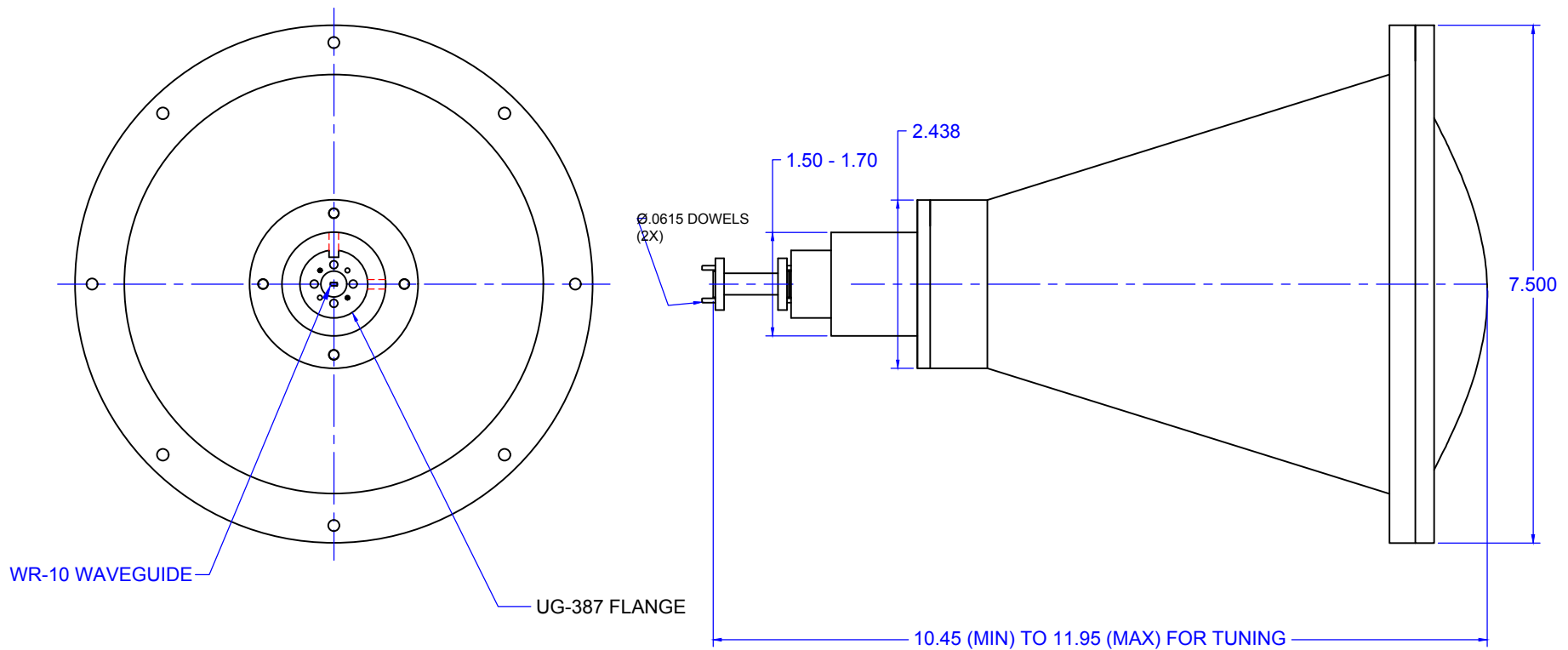

WR-10 WAVEGUIDE

UG-387 FLANGE

Ø.0615 DOWELS
(2X)

1.50 - 1.70

2.438

7.500

10.45 (MIN) TO 11.95 (MAX) FOR TUNING

ALL DIMENSIONS ARE
REFERENCE ONLY

UNLESS OTHERWISE SPECIFIED
ALL SURFACES $\sqrt{32}$
DIMENSIONS ARE IN INCHES
TOLERANCES ARE:
DECIMALS: .1234 +/- .0005
.123 +/- .005
.12 +/- .01
ANGLES: +/- .5 DEGREES
ALL THREADS TO BE 2A OR 2B
REF DWG# --
ORIGINAL DWG# 20108e

THIRD ANGLE PROJECTION	
DRAFTING: J. VOLZ	
APPROVED: M.S.	
DATE: 8-23-18	
SHEET NO.	OF
1	1

Mi-Wave Millimeter Products Inc.	
TITLE	
258W-6-94/387 OUTLINE	
SIZE	DWG NO
A	24226