

REVISIONS			
REV	DESCRIPTION	DATE	APPROVED
A	CORRECT GEOMETRY	1-16-19	MS

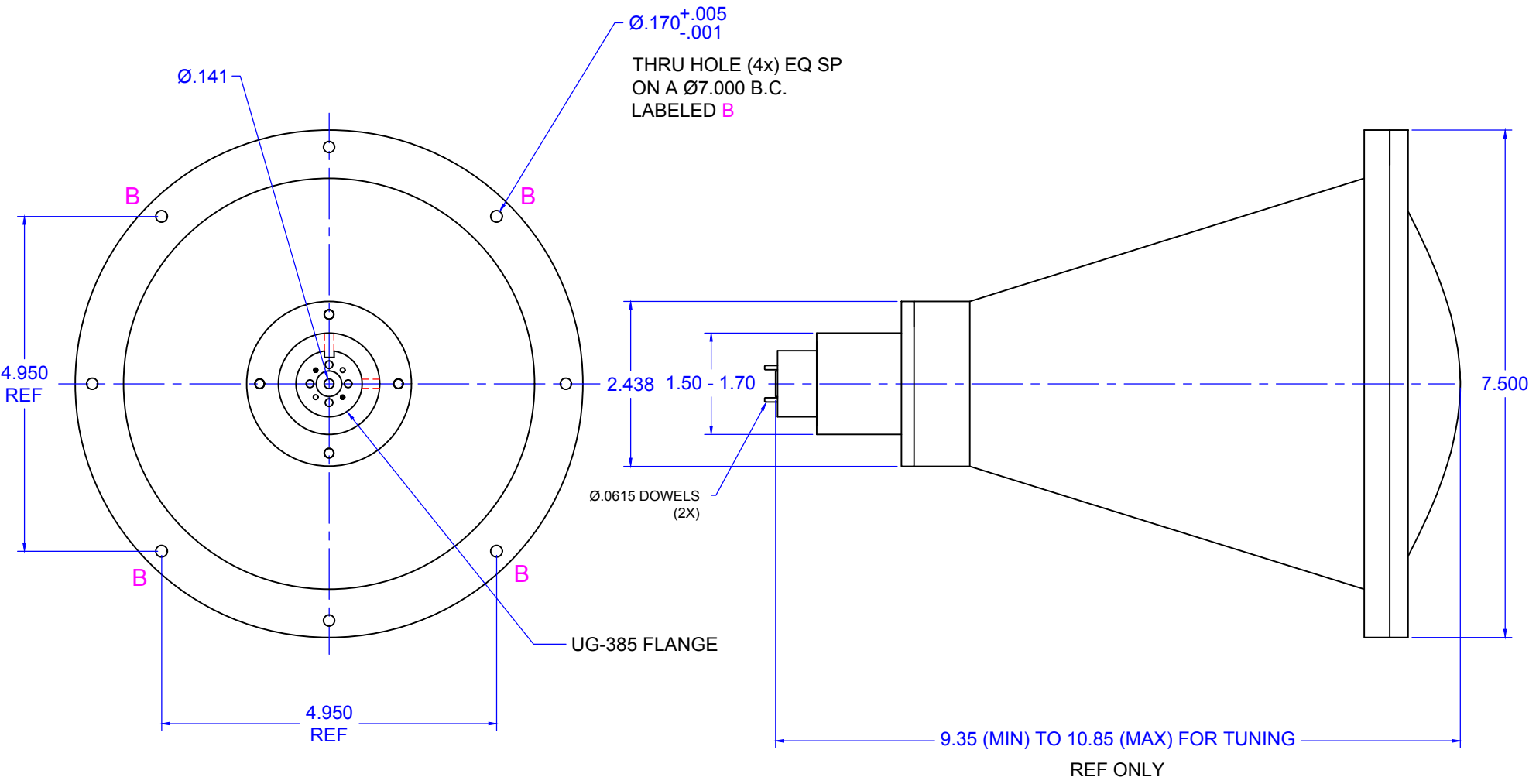

ALL DIMENSIONS ARE
REFERENCE ONLY

UNLESS OTHERWISE SPECIFIED ALL SURFACES $\frac{32}{\sqrt{\quad}}$		 THIRD ANGLE PROJECTION		Mi-Wave Millimeter Products Inc.		
DIMENSIONS ARE IN INCHES TOLERANCES ARE: DECIMALS: .1234 +/- .0005 .123 +/- .005 .12 +/- .01 ANGLES: +/- .5 DEGREES ALL THREADS TO BE 2A OR 2B				DRAFTING: J. VOLZ		TITLE
REF DWG# --		APPROVED: M.S.		258V-6-60-.141/385 OUTLINE		
ORIGINAL DWG# 20108e		DATE: 8-23-18				
SHEET NO. 1		OF 1		SIZE A	DWG NO 24216	REV A