

REVISIONS

REV	DESCRIPTION	DATE	APPROVED
-	-	-	-

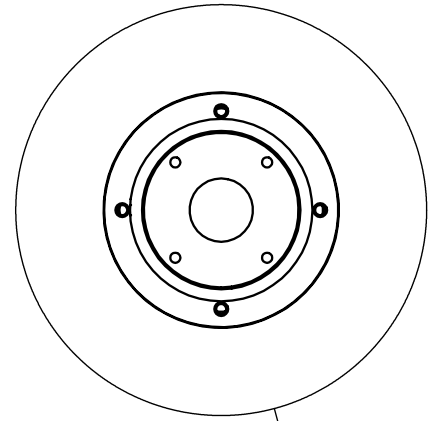

DETAIL C
SCALE 1:2

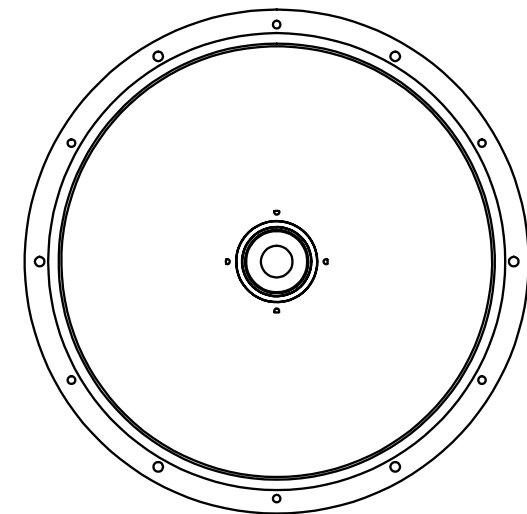
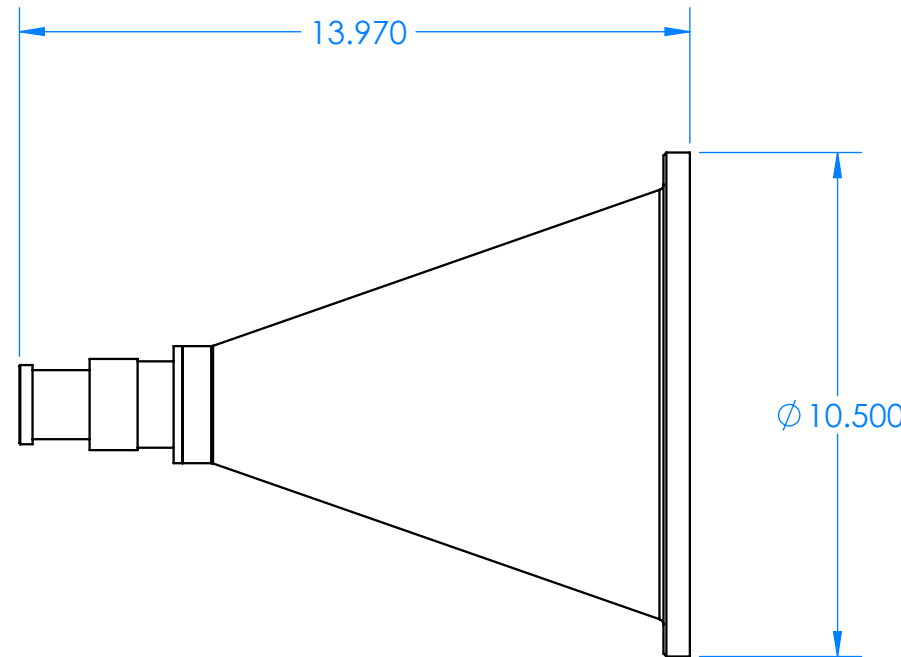
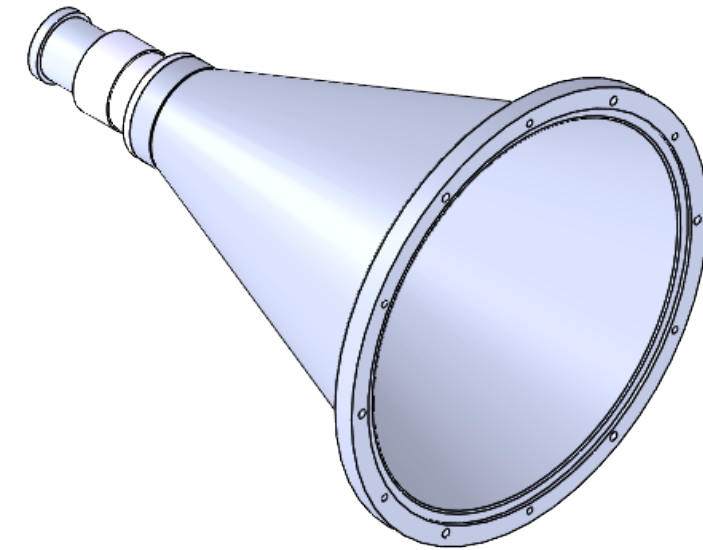
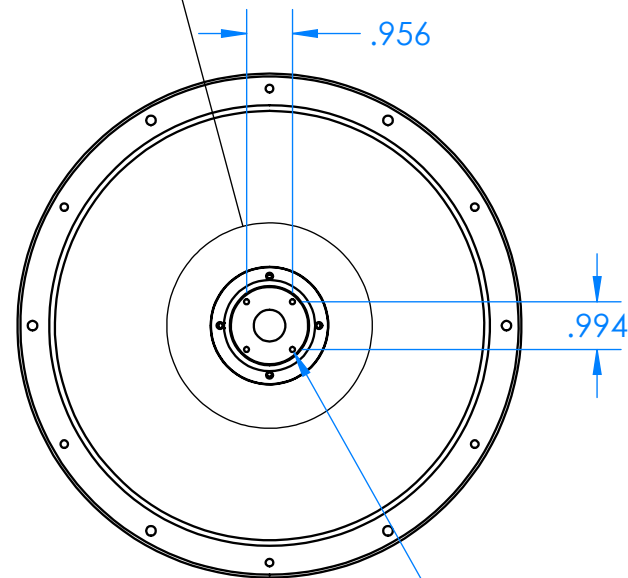

DECIMALS: XXXX ±.0005 XXX ±.005 XX ±.01	ANGLES: ±.5 DEGRESS	THIRD ANGLE PROJECTION	<table border="1"> <tr> <th>NAME</th> <th>DATE</th> </tr> <tr> <td>DRAWN JV</td> <td>4-19-21</td> </tr> <tr> <td>CHECKED MS</td> <td>4-19-21</td> </tr> <tr> <td>ENG MS</td> <td>4-19-21</td> </tr> </table>	NAME	DATE	DRAWN JV	4-19-21	CHECKED MS	4-19-21	ENG MS	4-19-21	TITLE: Millimeter Wave Products Inc. DWG. NO. 258KU-9-.660-419_OUTLINE_27686 SCALE: 1:4	REV: - SHEET 1 OF 1
NAME	DATE												
DRAWN JV	4-19-21												
CHECKED MS	4-19-21												
ENG MS	4-19-21												
MATERIAL: 6061 T6 ALUMINUM			WEIGHT:										