

REVISIONS			
REV	DESCRIPTION	DATE	APPROVED
A	INCREASE LENGTH	2/23/2017	M.S.

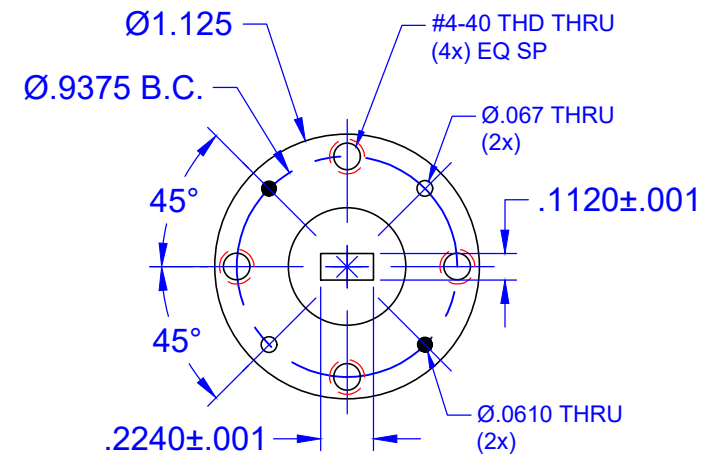
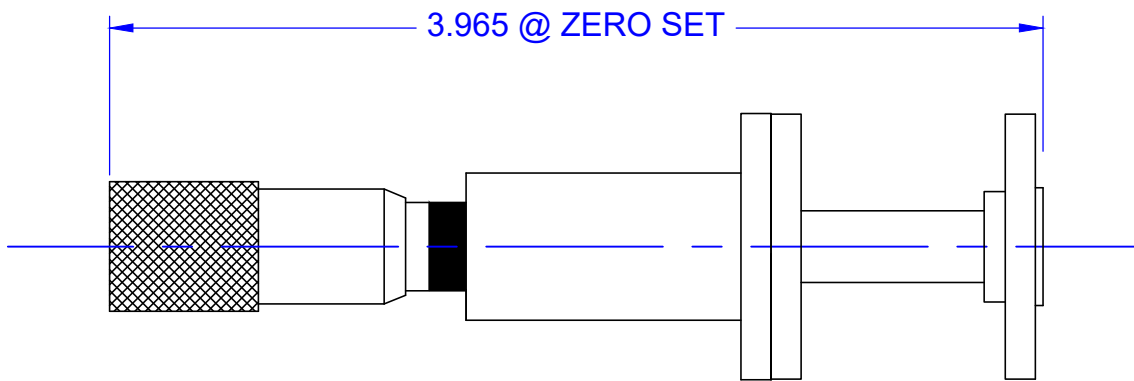

UNLESS OTHERWISE SPECIFIED ALL SURFACES $\sqrt{32}$
DIMENSIONS ARE IN INCHES TOLERANCES ARE: DECIMALS: .1234 +/- .0005 .123 +/- .005 .12 +/- .01 ANGLES: +/- .5 DEGREES
ALL THREADS TO BE 2A OR 2B
REF DWG# --
ORIGINAL DWG# 20011e

	THIRD ANGLE PROJECTION
DRAFTING: K.S.	
APPROVED: M.S.	
DATE: 2/23/2017	
SHEET NO. 1	OF 1

Mi-Wave Millimeter Products Inc.	
TITLE <b>590B/383 OUTLINE</b>	
SIZE <b>A</b>	DWG NO <b>27123</b>