

REVISIONS			
REV	DESCRIPTION	DATE	APPROVED
-	-	-	-

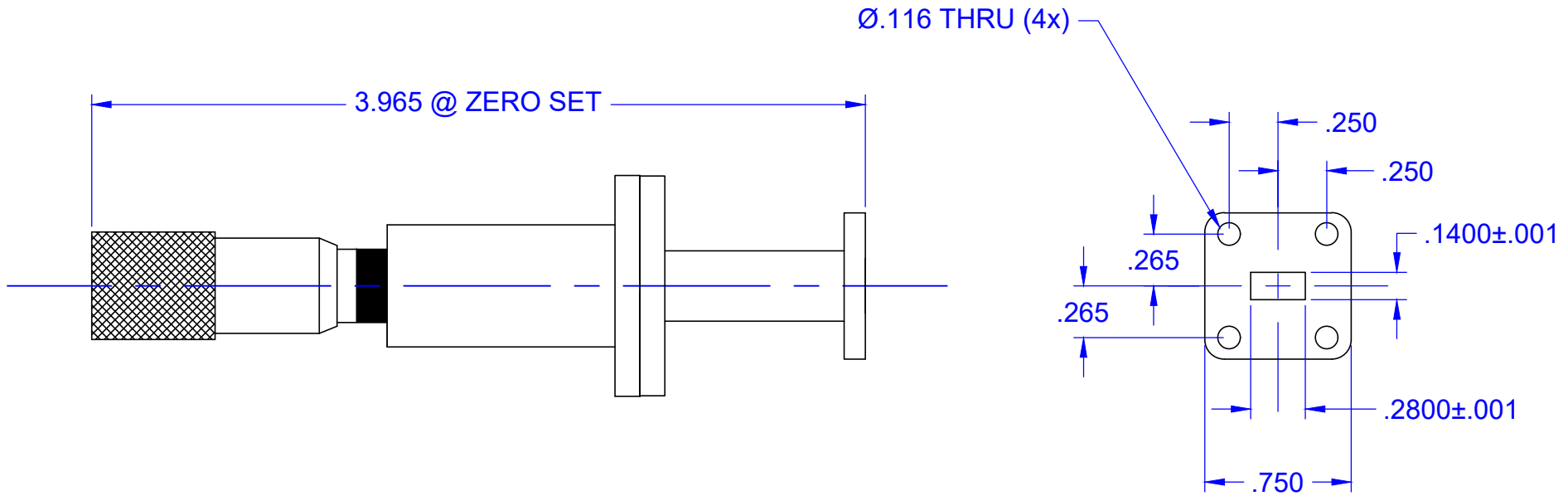

UNLESS OTHERWISE SPECIFIED ALL SURFACES $\sqrt{32}$		 THIRD ANGLE PROJECTION		<b>Mi-Wave</b> Millimeter Products Inc.	
DIMENSIONS ARE IN INCHES TOLERANCES ARE: DECIMALS: .1234 +/- .0005 .123 +/- .005 .12 +/- .01 ANGLES: +/- .5 DEGREES		DRAFTING: MRN		TITLE  <h1>590A/599 OUTLINE</h1>	
ALL THREADS TO BE 2A OR 2B		APPROVED: M.S.			
REF DWG# --	SHEET NO. 1	OF 1	DATE: 11/25/2009	SIZE A	DWG NO 27124
ORIGINAL DWG# 20011e					