

REVISIONS			
REV	DESCRIPTION	DATE	APPROVED
--	--	--	--

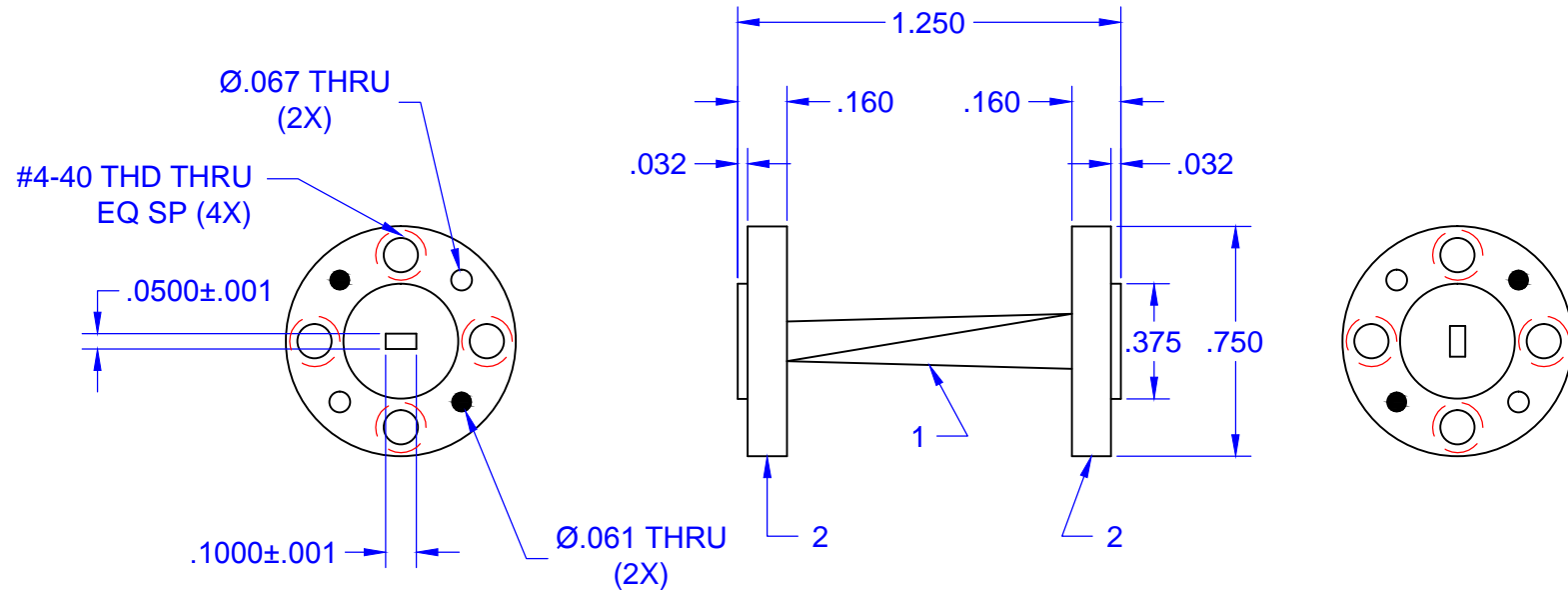

2	STOCK	UG387 FLANGE	2	
1	STOCK	WR-10 WAVEGUIDE	1	
QTY	PART NUMBER	DESCRIPTION	ITEM	
UNLESS OTHERWISE SPECIFIED ALL SURFACES $\sqrt{32}$		 THIRD ANGLE PROJECTION	Mi-Wave Millimeter Products Inc. 681W-387 OUTLINE	
DIMENSIONS ARE IN INCHES TOLERANCES ARE: DECIMALS: .1234 +/- .0005 .123 +/- .005 .12 +/- .01 ANGLES: +/- .5 DEGREES				DRAFTING: K.S. APPROVED: M.S. DATE: 1/14/2015
ALL THREADS TO BE 2A OR 2B		SHEET NO. 1 OF 1		SIZE A DWG NO 22699
REF DWG #: 12171				