

REVISIONS			
REV	DESCRIPTION	DATE	APPROVED
--	--	--	--

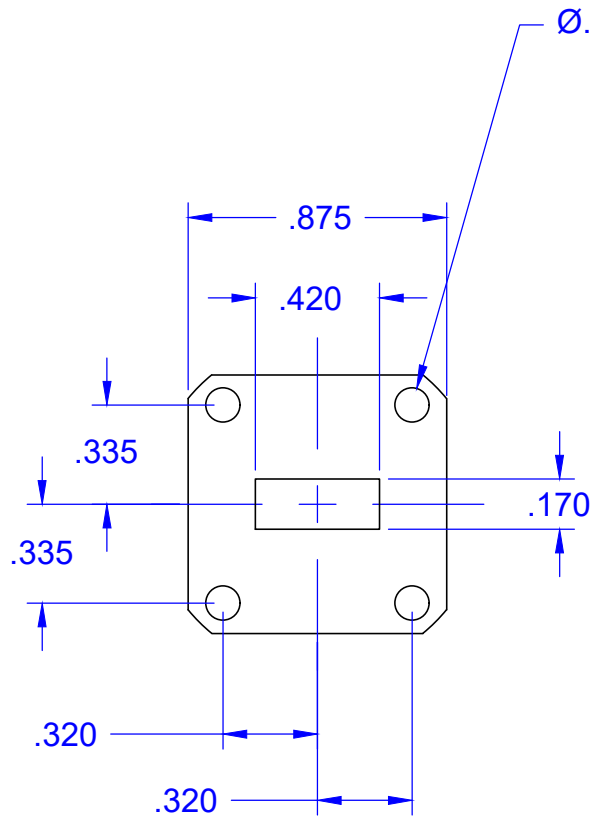

UG 595 FLANGE

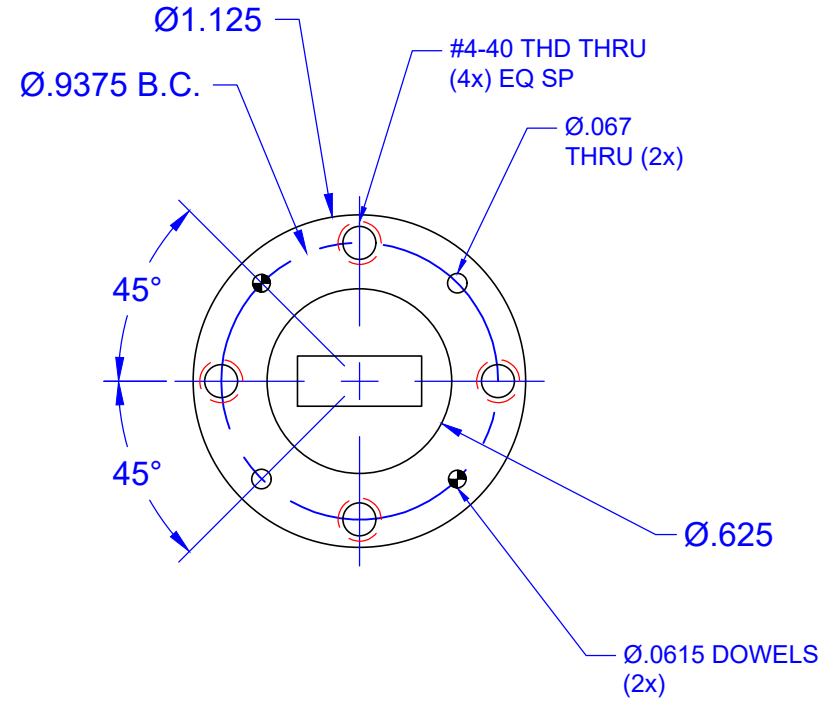
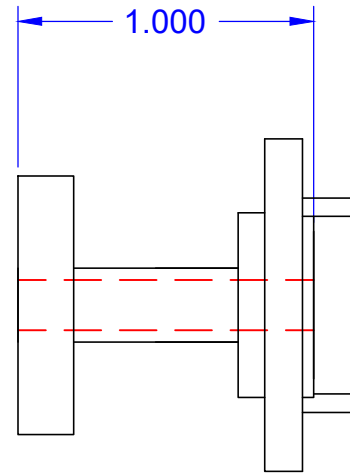

UG 425 FLANGE

QTY	PART NUMBER	DESCRIPTION		ITEM
UNLESS OTHERWISE SPECIFIED ALL SURFACES $\sqrt{32}$		<p>THIRD ANGLE PROJECTION</p> <p><b>Mi-Wave</b> Millimeter Products Inc.</p>		
DIMENSIONS ARE IN INCHES TOLERANCES ARE:				
DECIMALS: .1234 +/- .0005 .123 +/- .005 .12 +/- .01				
ANGLES: +/- .5 DEGREES				
ALL THREADS TO BE 2A OR 2B		DATE: 8-13-21		TITLE
REF DWG# --		DRAFTING: C.C.	<p><b>688K-595-425</b> <b>OUTLINE</b></p>	
ORIGINAL DWG# 20016		APPROVED: M.S.		
		DATE: 8-13-21		
		SHEET NO. 1	OF 1	SIZE A
				DWG NO 26114