

| REVISIONS |             |      |          |
|-----------|-------------|------|----------|
| REV       | DESCRIPTION | DATE | APPROVED |
| --        | --          | --   | --       |

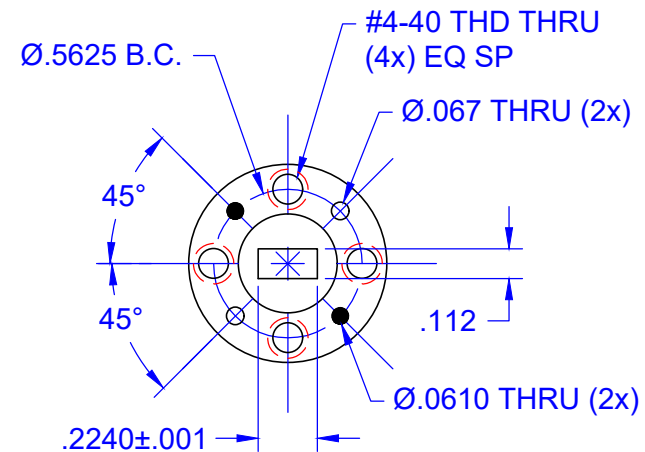
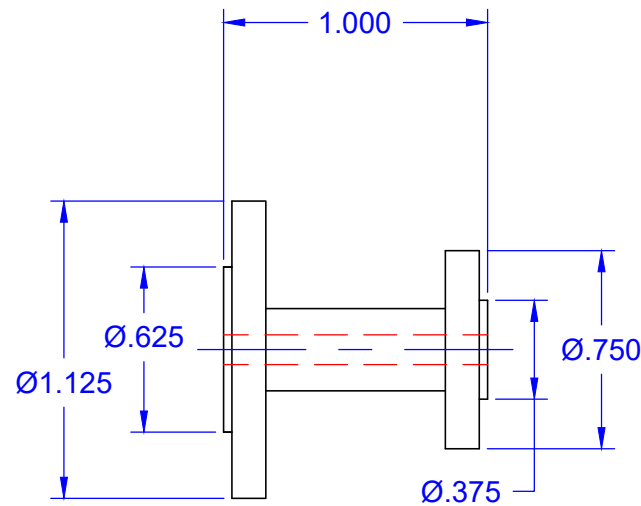
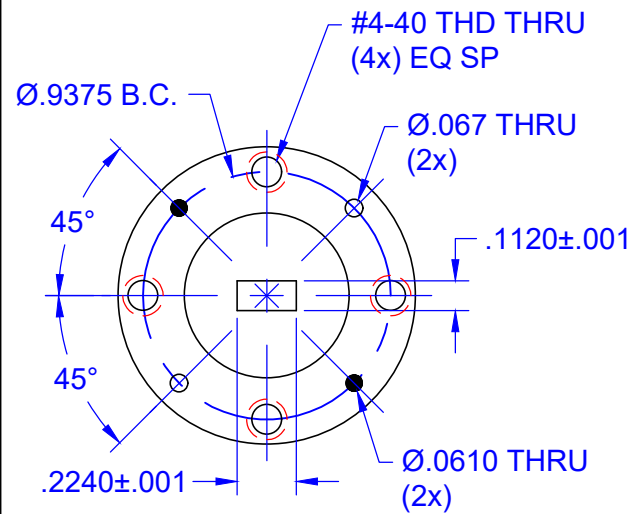
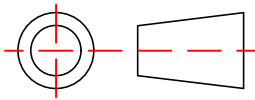

| QTY  | PART NUMBER | MATERIAL: 1/2 HARD BRASS  |    | DESCRIPTION                              | ITEM   |
|--|-------------|---|----|--|--------|
| --   | --          |   |    |  |        |
| UNLESS OTHERWISE SPECIFIED<br>ALL SURFACES $\sqrt{32}$   |             | <br>THIRD ANGLE PROJECTION |    | <b>Mi-Wave</b> Millimeter Products Inc.  |        |
| DIMENSIONS ARE IN INCHES<br>TOLERANCES ARE:<br>DECIMALS: .1234 +/- .0005<br>.123 +/- .005<br>.12 +/- .01<br>ANGLES: +/- .5 DEGREES |             | DRAFTING: MRN<br>APPROVED: M.S.<br>DATE: 9/28/2011  |    | TITLE<br><b>688B/383/385<br/>OUTLINE</b> |        |
| ALL THREADS TO BE 2A OR 2B   |             | SHEET NO.   | OF | SIZE                                     | DWG NO |
| REF DWG# --  |             | 1   | 1  | A  | 26105  |