

REVISIONS			
REV	DESCRIPTION	DATE	APPROVED
--	--	--	--

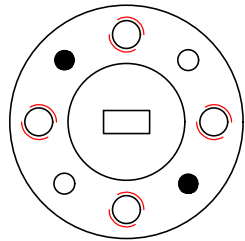

UG-385_FLANGE

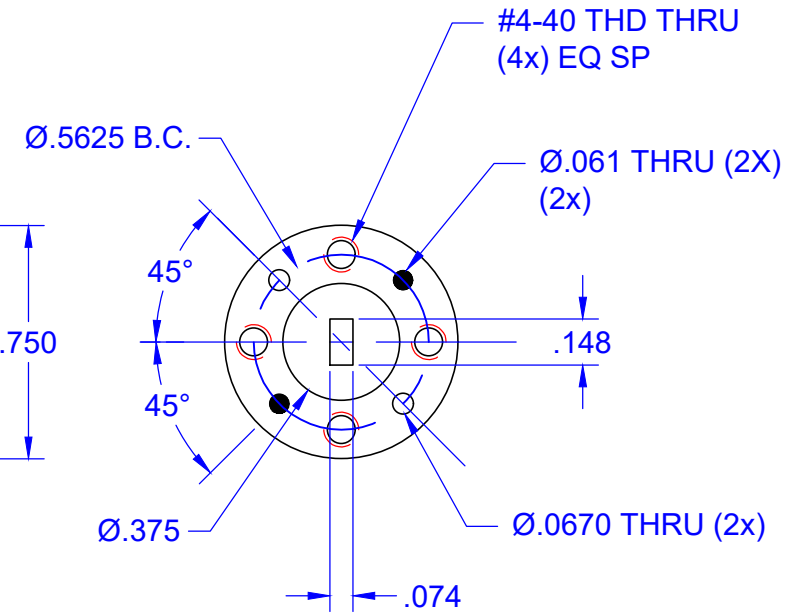
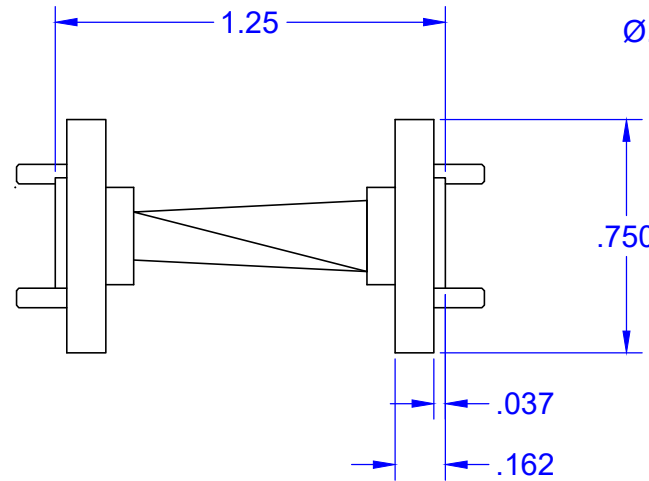

UG-385_FLANGE

ALL DIMENSIONS ARE REFERENCE ONLY

UNLESS OTHERWISE SPECIFIED ALL SURFACES $\sqrt{32}$	 THIRD ANGLE PROJECTION	Mi-Wave Millimeter Products Inc.	
		TITLE 681V-LH-385 OUTLINE	
DIMENSIONS ARE IN INCHES TOLERANCES ARE: DECIMALS: .1234 +/- .0005 .123 +/- .005 .12 +/- .01 ANGLES: +/- .5 DEGREES	DRAFTING: C.C.	SIZE	DWG NO
ALL THREADS TO BE 2A OR 2B	APPROVED: M.S.	A	26262
REF DWG #: -	DATE: 10-28-21		
	SHEET NO. 1 OF 1		