

REVISIONS			
REV	DESCRIPTION	DATE	APPROVED
--	--	--	--

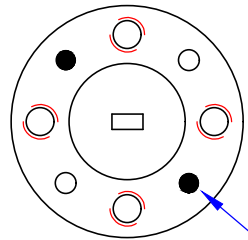

UG-387_FLANGE

Ø.0615 DOWELS
(2x)

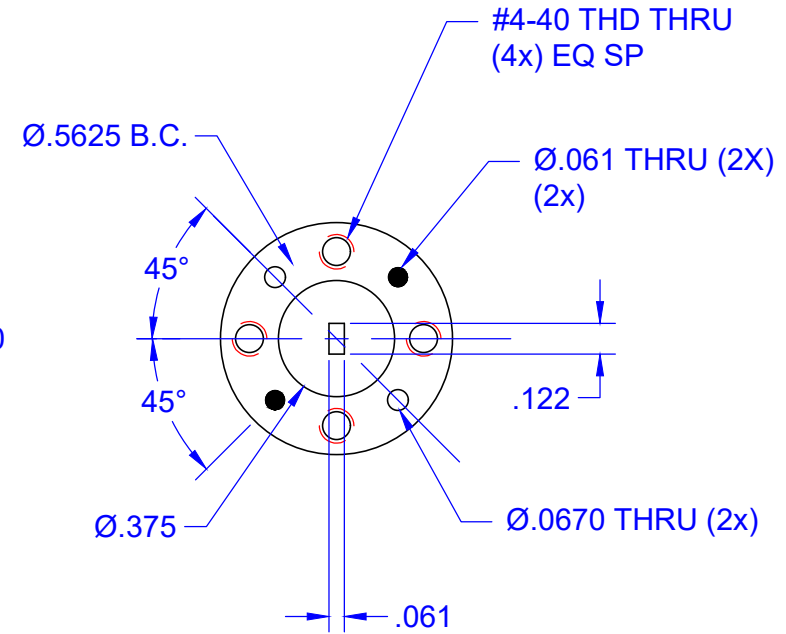
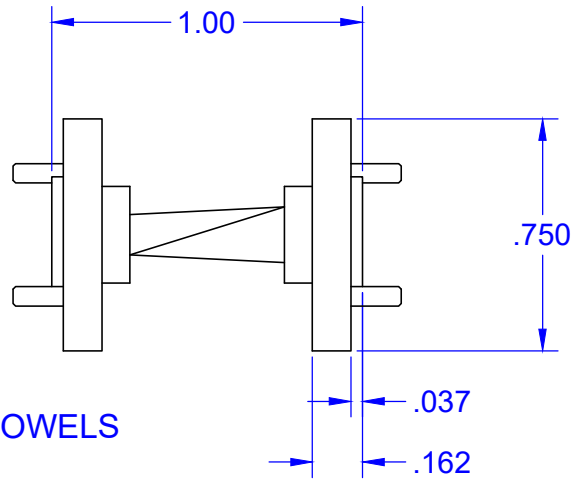

UG-387_FLANGE

ALL DIMENSIONS ARE REFERENCE ONLY

UNLESS OTHERWISE SPECIFIED ALL SURFACES $\sqrt{32}$	 THIRD ANGLE PROJECTION	Mi-Wave Millimeter Products Inc.	
		TITLE 681E-RH-387 OUTLINE	
DIMENSIONS ARE IN INCHES TOLERANCES ARE: DECIMALS: .1234 +/- .0005 .123 +/- .005 .12 +/- .01 ANGLES: +/- .5 DEGREES	DRAFTING: J.V.	DATE: 9-20-19	
ALL THREADS TO BE 2A OR 2B	APPROVED: M.S.	SHEET NO.	OF
REF DWG #: -		1	1
	SIZE	DWG NO	
	A	25562	