

REVISIONS			
REV	DESCRIPTION	DATE	APPROVED
--	--	--	--

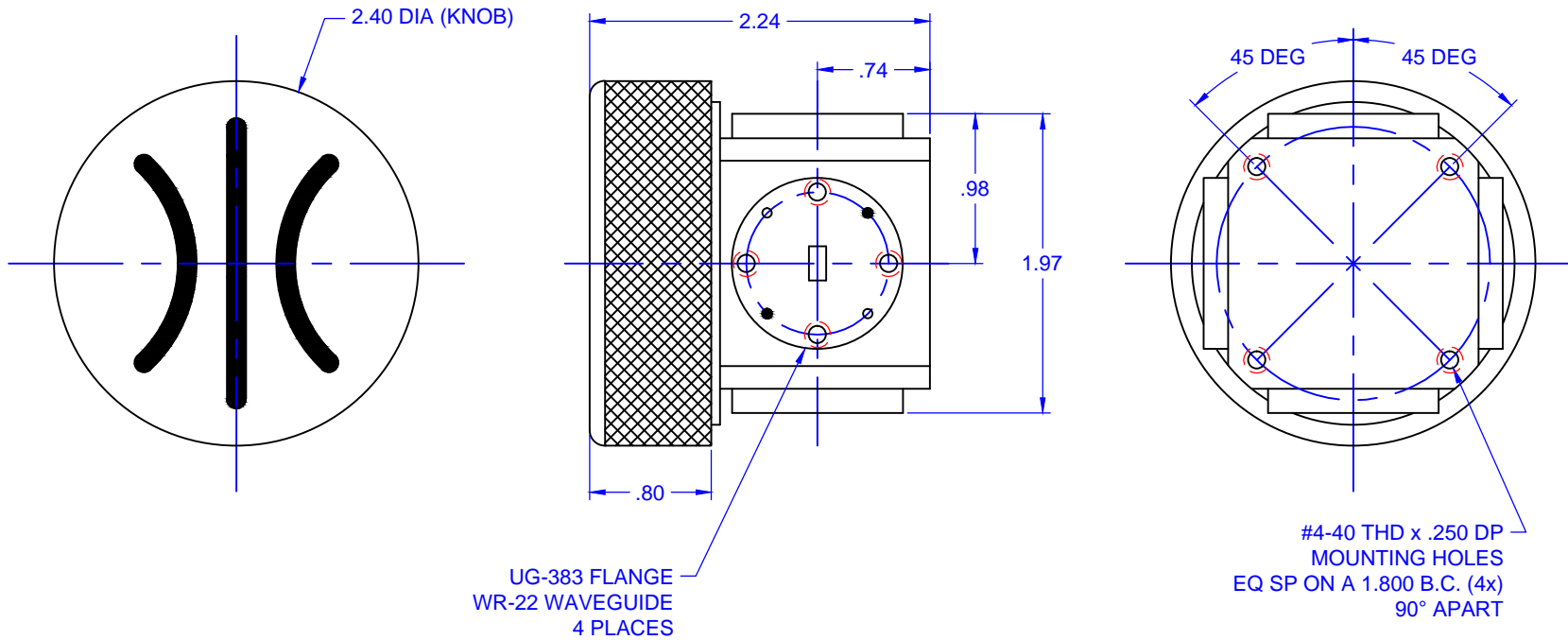
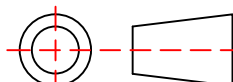

--		OUTLINE		--	
QTY	PART NUMBER	DESCRIPTION		ITEM	
UNLESS OTHERWISE SPECIFIED		 THIRD ANGLE PROJECTION		Mi-Wave Millimeter Products Inc. TITLE 530B/383 OUTLINE	
ALL SURFACES $\sqrt{32}$					
DIMENSIONS ARE IN INCHES TOLERANCES ARE: DECIMALS: .1234 +/- .0005 .123 +/- .005 .12 +/- .01 ANGLES: +/- .5 DEGREES					
ALL THREADS TO BE 2A OR 2B					
REF DWG# --		DATE: 1/14/2010		SIZE	
ORIGINAL DWG# 20077		SHEET NO. 1 OF 1		DWG NO 20108	