

REVISIONS			
REV	DESCRIPTION	DATE	APPROVED
--	--	--	--

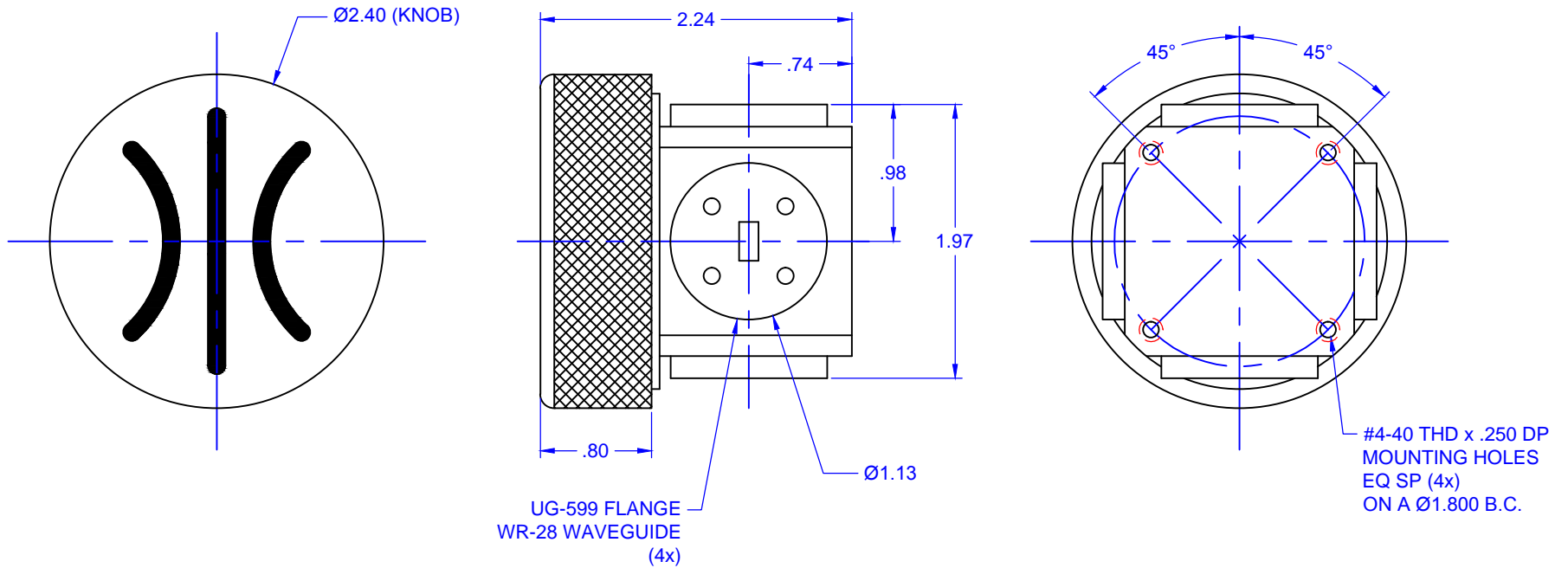

--	--	OUTLINE		--
QTY	PART NUMBER	DESCRIPTION		ITEM
UNLESS OTHERWISE SPECIFIED				
ALL SURFACES			Mi-Wave Millimeter Products Inc.	
DIMENSIONS ARE IN INCHES			TITLE	
TOLERANCES ARE:			530A/599	
DECIMALS: .1234 +/- .0005		DRAFTING: MRN	OUTLINE	
.123 +/- .005		APPROVED: M.S.		
.12 +/- .01		DATE: 1/14/2010		
ANGLES: +/- .5 DEGREES				
ALL THREADS TO BE 2A OR 2B				
REF DWG# --	SHEET NO.	OF	SIZE	DWG NO
ORIGINAL DWG# 20076	1	1	A	20107