

REVISIONS			
REV	DESCRIPTION	DATE	APPROVED
-	-	-	-

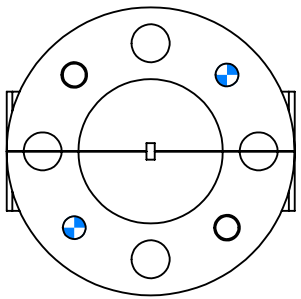

UG-387

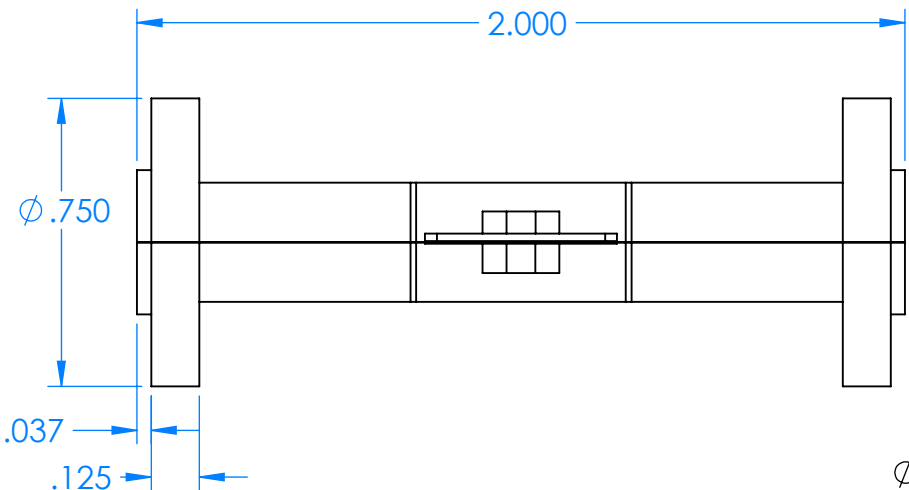
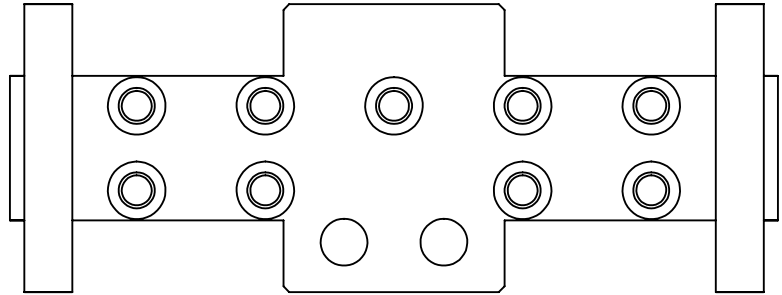
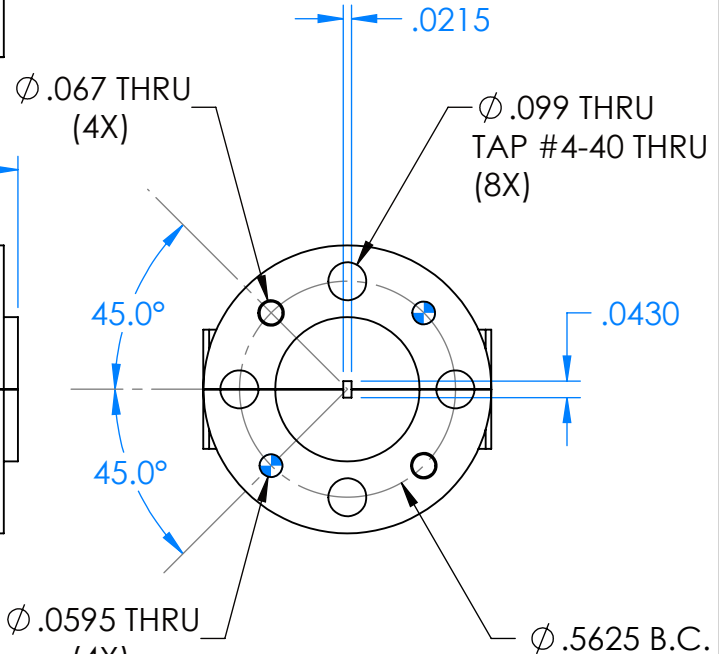

UG-387

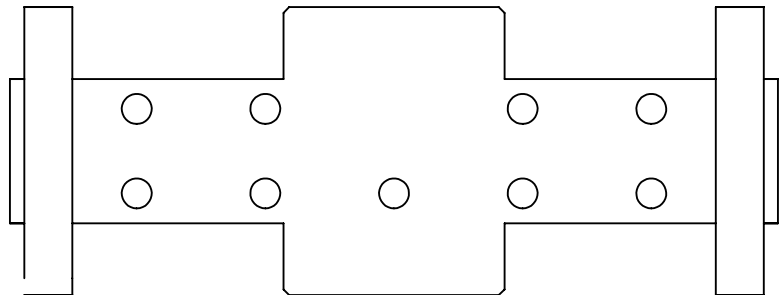

DECIMALS: XXXX ±.0005 XXX ±.005 XX ±.01	NAME	DATE
ANGLES: ± .5 DEGRESS	DRAWN	JV 1-10-19
THIRD ANGLE PROJECTION	CHECKED	MS 1-10-19
	ENG	LS 1-10-19
	MATL:	6061 T6 ALUMINUM

TITLE:	Millimeter Wave Products Inc.	
SIZE	DWG. NO.	REV
A	521H-387-OUTLINE_24473	-
SCALE: 2:1	WEIGHT:	SHEET 1 OF 1