

REVISIONS			
REV	DESCRIPTION	DATE	APPROVED
--	--	--	--

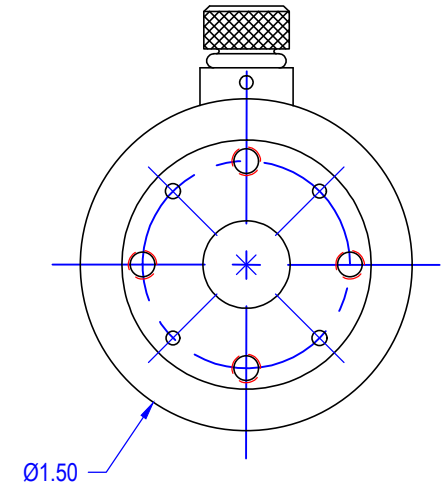
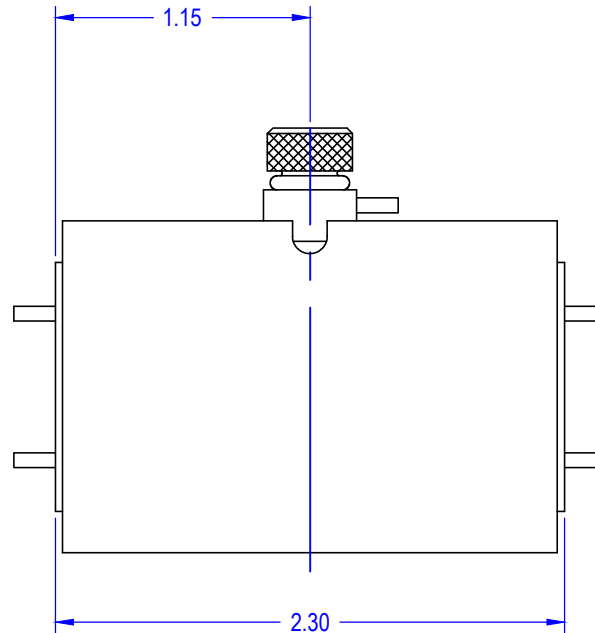
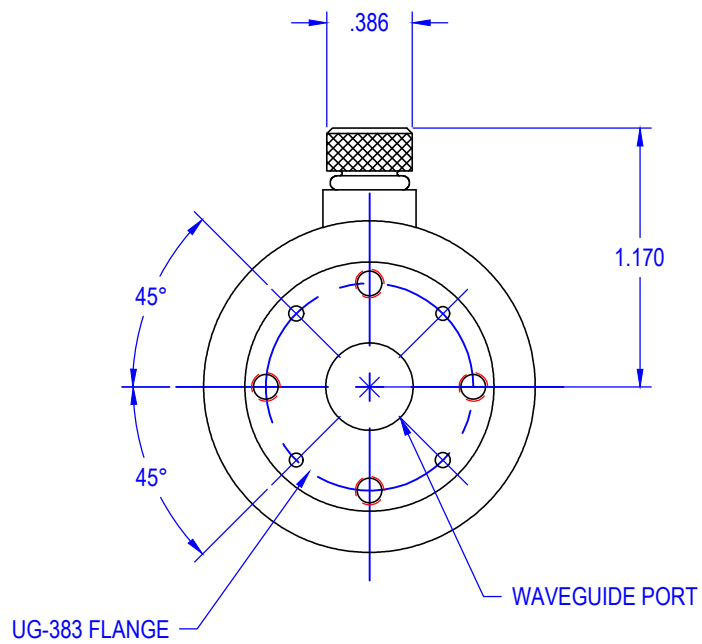

CIRCULAR WAVEGUIDE PORT INNER DIAMETER
0.328
0.396
0.470

QTY	PART NUMBER	OUTLINE DESCRIPTION	ITEM
--	--	OUTLINE DESCRIPTION	--
UNLESS OTHERWISE SPECIFIED		 THIRD ANGLE PROJECTION	Millimeter Products Inc. 283K-383 OUTLINE
ALL SURFACES $\sqrt{32}$			
DIMENSIONS ARE IN INCHES		DRAFTING: K.S.	TITLE 283K-383 OUTLINE
TOLERANCES ARE:		APPROVED: M.S.	
DECIMALS: .1234 +/- .0005		DATE: 8/13/2015	
.123 +/- .005		SHEET NO. 1 OF 1 SIZE A DWG NO 25694	
.12 +/- .01			
ANGLES: +/- .5 DEGREES			
ALL THREADS TO BE 2A OR 2B			
REF DWG# 13116			