

REVISIONS			
REV	DESCRIPTION	DATE	APPROVED
--	--	--	--

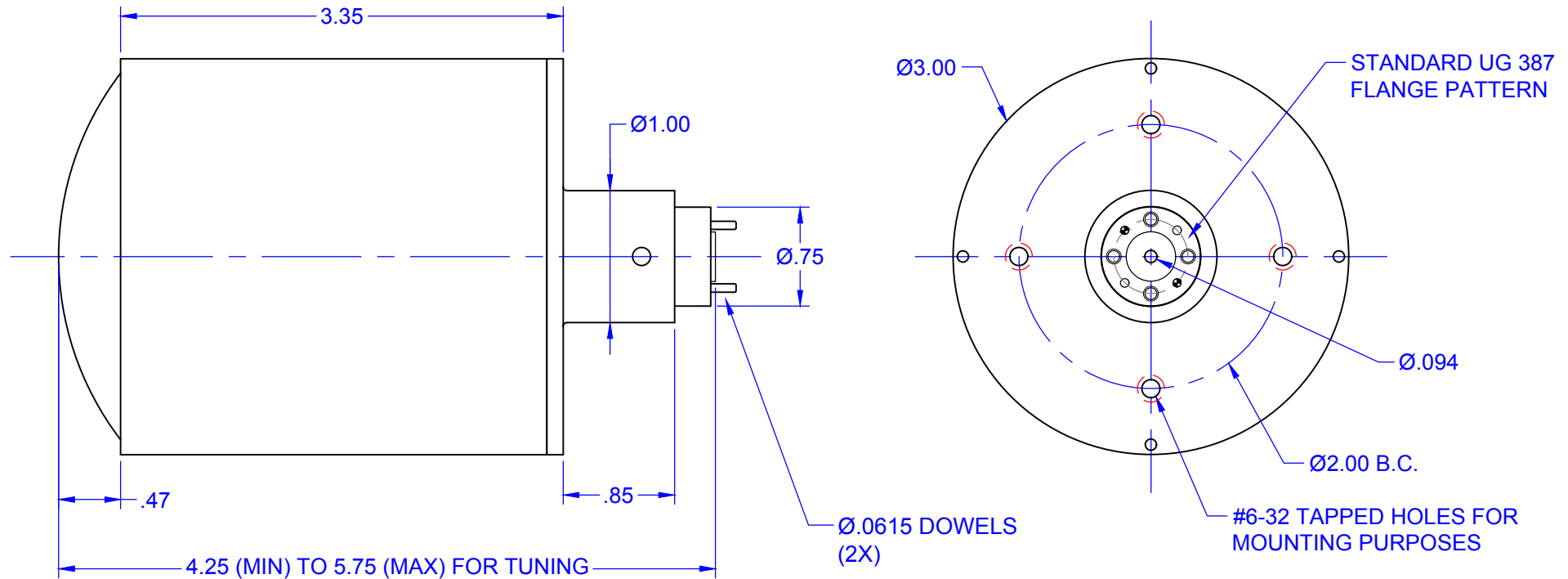

ALL DIMENSIONS ARE  
REFERENCE ONLY

QTY	PART NUMBER	OUTLINE		DESCRIPTION	ITEM
--	--				--
UNLESS OTHERWISE SPECIFIED		 THIRD ANGLE PROJECTION		<b>Mi-Wave</b> Millimeter Products Inc.  <b>258W-3-94-.094-387</b> <b>OUTLINE</b>	
ALL SURFACES $\sqrt{32}$					
DIMENSIONS ARE IN INCHES		DRAFTING: JV		TITLE <b>258W-3-94-.094-387</b> <b>OUTLINE</b>	
TOLERANCES ARE:		APPROVED: M.S.			
DECIMALS: .1234 +/- .0005		DATE: 8-24-18			
.123 +/- .005		SHEET NO. 1		SIZE	DWG NO
.12 +/- .01		OF 1		<b>A</b>	<b>24224</b>
ANGLES: +/- .5 DEGREES		REF DWG# 13649			
ALL THREADS TO BE 2A OR 2B					

REVISIONS			
REV	DESCRIPTION	DATE	APPROVED
--	--	--	--

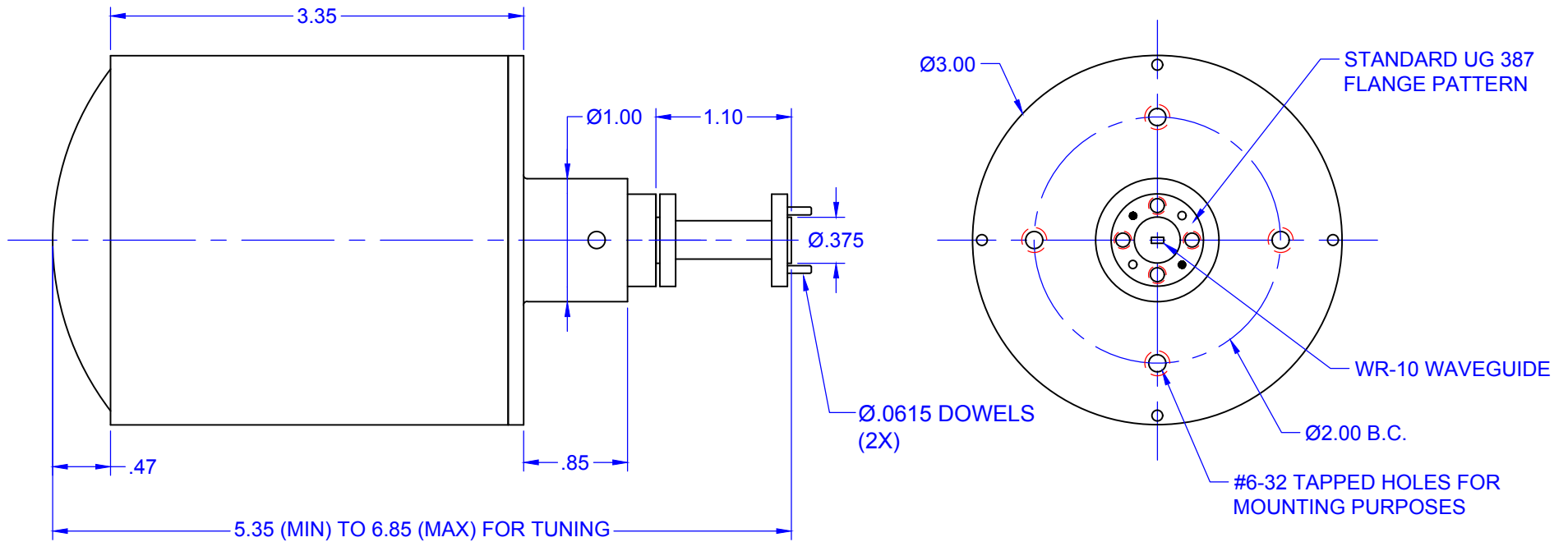

ALL DIMENSIONS ARE  
REFERENCE ONLY

QTY	PART NUMBER	OUTLINE		DESCRIPTION	ITEM
UNLESS OTHERWISE SPECIFIED		 THIRD ANGLE PROJECTION		Mi-Wave Millimeter Products Inc.	
ALL SURFACES $\sqrt{32}$				TITLE	
DIMENSIONS ARE IN INCHES		DRAFTING: K.S.		258W-3-94-387	
TOLERANCES ARE:		APPROVED: M.S.			
DECIMALS: .1234 +/- .0005		DATE: 11/13/2013		OUTLINE	
.123 +/- .005		SHEET NO. 1 OF 1			
.12 +/- .01		SIZE A		DWG NO 22162	
ANGLES: +/- .5 DEGREES		REF DWG# 13649			
ALL THREADS TO BE 2A OR 2B					

REVISIONS			
REV	DESCRIPTION	DATE	APPROVED
--	--	--	--

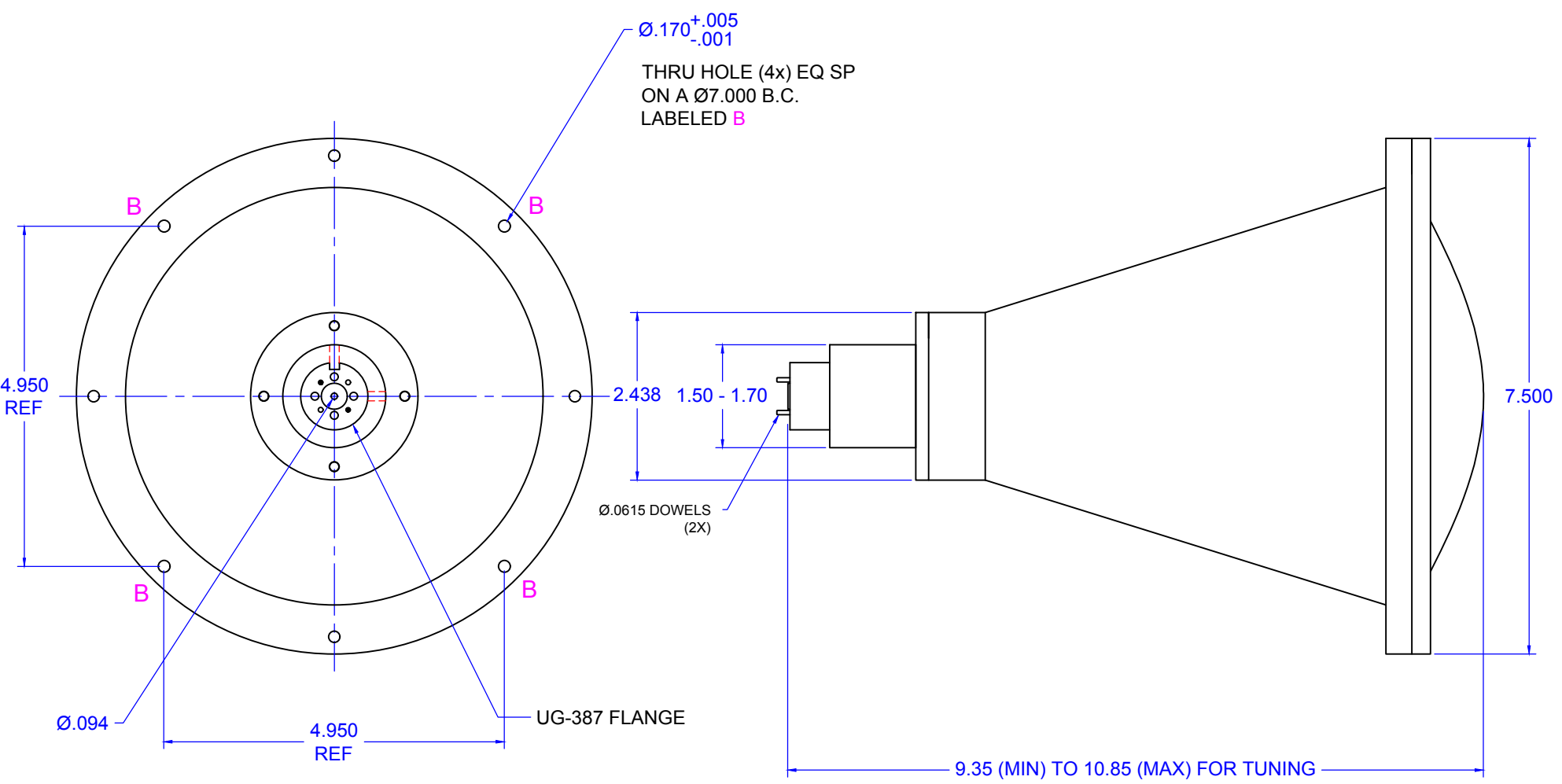

ALL DIMENSIONS ARE  
REFERENCE ONLY

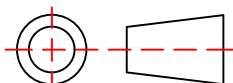
UNLESS OTHERWISE SPECIFIED ALL SURFACES $32/\sqrt{\quad}$		 THIRD ANGLE PROJECTION	Mi-Wave Millimeter Products Inc.	
DIMENSIONS ARE IN INCHES TOLERANCES ARE: DECIMALS: .1234 +/- .0005 .123 +/- .005 .12 +/- .01 ANGLES: +/- .5 DEGREES ALL THREADS TO BE 2A OR 2B			TITLE <b>258W-6-94-.094/387 OUTLINE</b>	
REF DWG# --		DRAFTING: J. VOLZ		SIZE <b>A</b>
ORIGINAL DWG# 20108e		APPROVED: M.S.		
		DATE: 8-23-18		DWG NO <b>24225</b>
		SHEET NO. 1	OF 1	

REVISIONS			
REV	DESCRIPTION	DATE	APPROVED
--	--	--	--

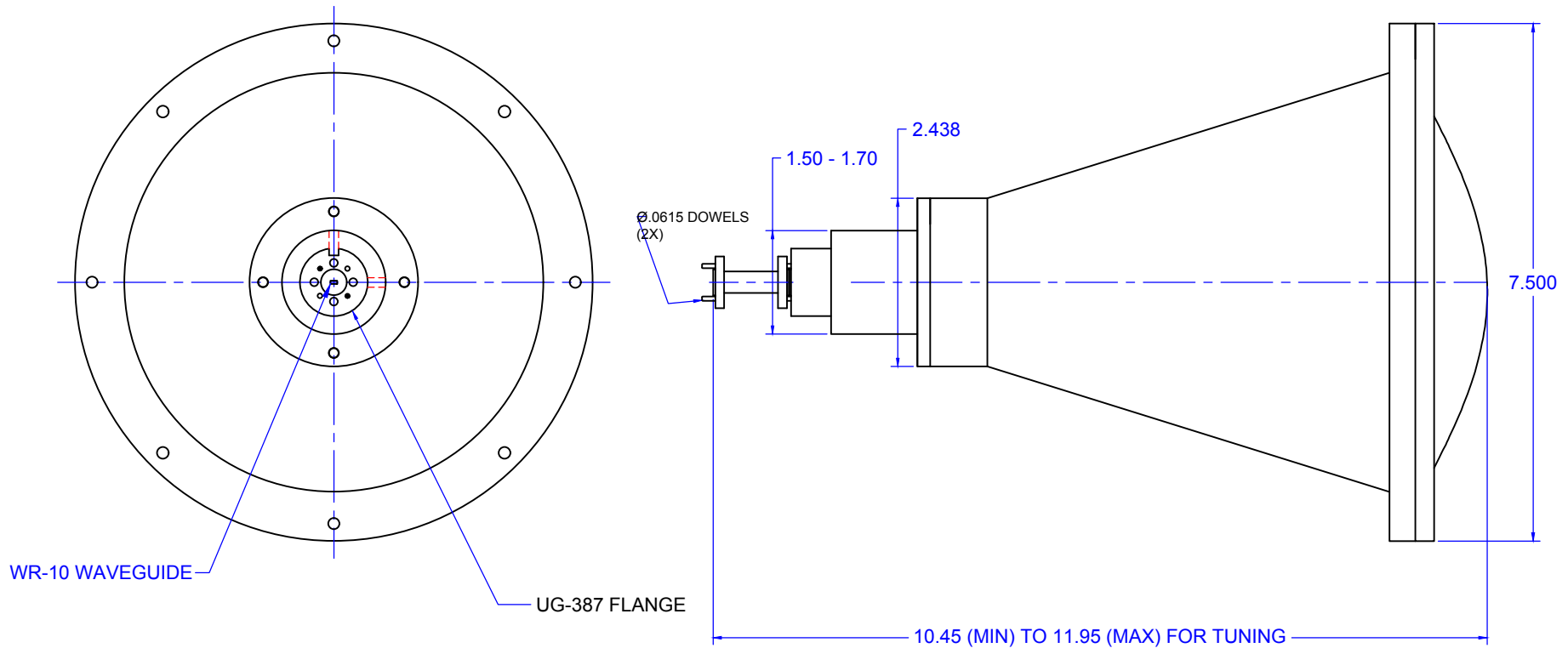

WR-10 WAVEGUIDE

UG-387 FLANGE

Ø.0615 DOWELS  
(2X)

ALL DIMENSIONS ARE  
REFERENCE ONLY

UNLESS OTHERWISE SPECIFIED ALL SURFACES 32		 THIRD ANGLE PROJECTION	Mi-Wave Millimeter Products Inc.	
DIMENSIONS ARE IN INCHES TOLERANCES ARE: DECIMALS: .1234 +/- .0005 .123 +/- .005 .12 +/- .01 ANGLES: +/- .5 DEGREES			TITLE <b>258W-6-94/387 OUTLINE</b>	
ALL THREADS TO BE 2A OR 2B		DRAFTING: J. VOLZ		
REF DWG# --		APPROVED: M.S.		
ORIGINAL DWG# 20108e		DATE: 8-23-18		
		SHEET NO. 1	OF 1	SIZE <b>A</b>
		DWG NO <b>24226</b>		

