

REVISIONS			
REV	DESCRIPTION	DATE	APPROVED
--	--	--	--

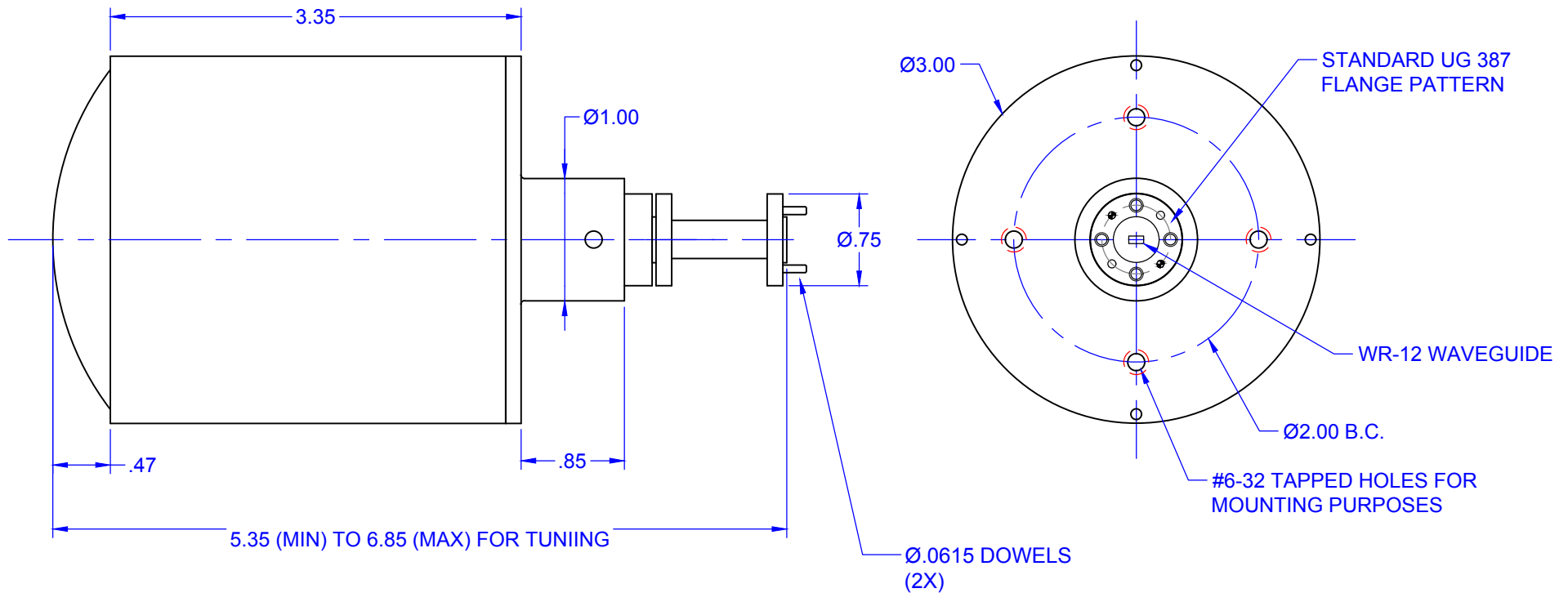

ALL DIMENSIONS ARE
REFERENCE ONLY

QTY	PART NUMBER	OUTLINE		DESCRIPTION	ITEM
				Mi-Wave Millimeter Products Inc.	
UNLESS OTHERWISE SPECIFIED				TITLE	
ALL SURFACES $\sqrt{32}$		DRAFTING:JV		258E-3-77-387	
DIMENSIONS ARE IN INCHES		APPROVED: M.S.		OUTLINE	
TOLERANCES ARE:		DATE: 8-23-18			
DECIMALS: .1234 +/- .0005		SHEET NO. 1 OF 1		SIZE A	DWG NO 24221
.123 +/- .005					
.12 +/- .01					
ANGLES: +/- .5 DEGREES					
ALL THREADS TO BE 2A OR 2B					
REF DWG# -					

REVISIONS			
REV	DESCRIPTION	DATE	APPROVED
--	--	--	--

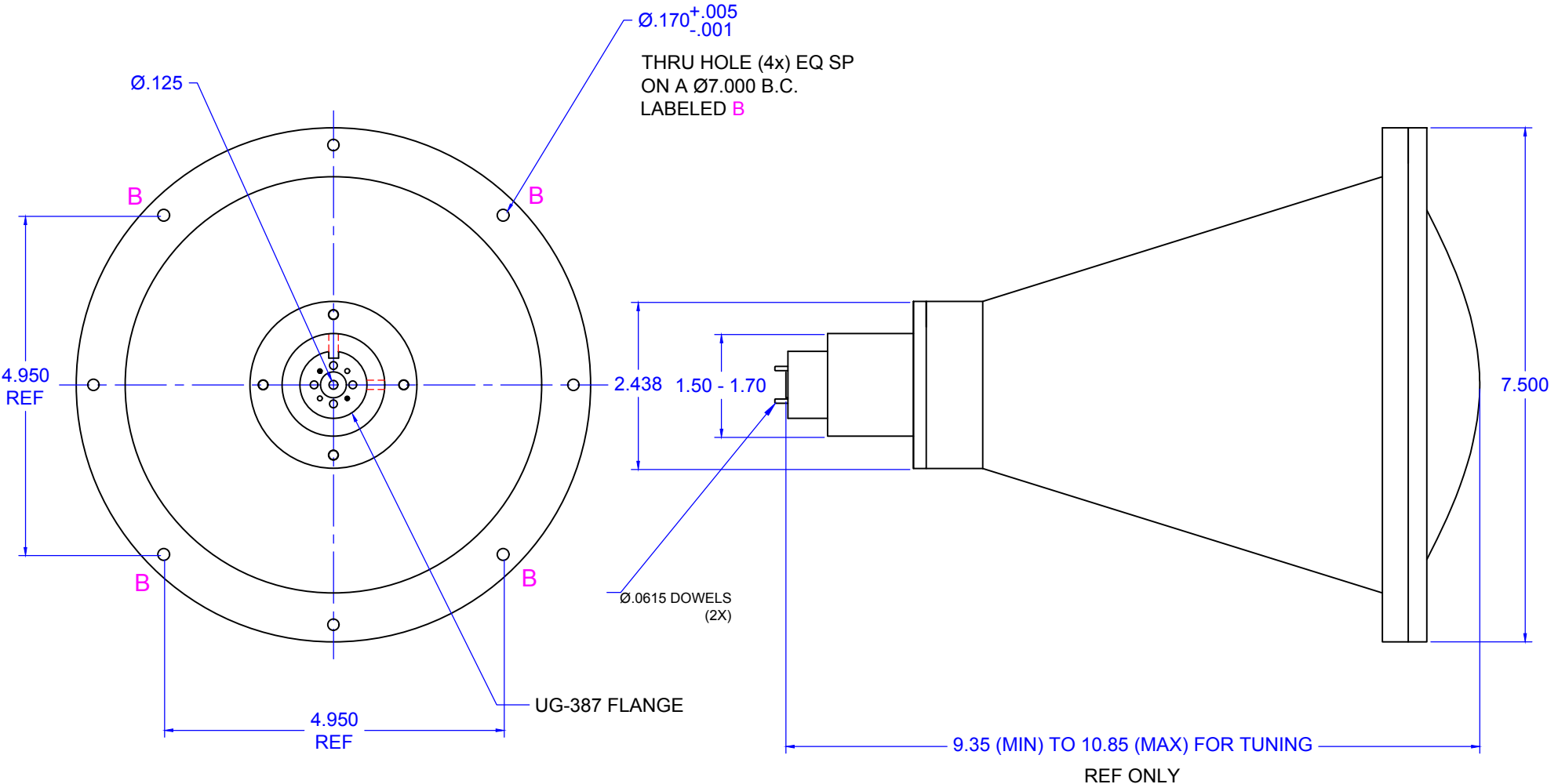

ALL DIMENSIONS ARE
REFERENCE ONLY

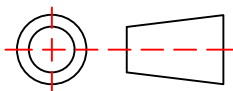
UNLESS OTHERWISE SPECIFIED ALL SURFACES $32/\sqrt{\quad}$		 THIRD ANGLE PROJECTION		Mi-Wave Millimeter Products Inc. TITLE	
DIMENSIONS ARE IN INCHES TOLERANCES ARE: DECIMALS: .1234 +/- .0005 .123 +/- .005 .12 +/- .01 ANGLES: +/- .5 DEGREES ALL THREADS TO BE 2A OR 2B		DRAFTING: J. VOLZ APPROVED: M.S. DATE: 8-23-18		258E-6-77-.125/387 OUTLINE	
REF DWG# --	SHEET NO. 1	OF 1	SIZE A	DWG NO 24222	
ORIGINAL DWG# 20108e					

REVISIONS			
REV	DESCRIPTION	DATE	APPROVED
--	--	--	--

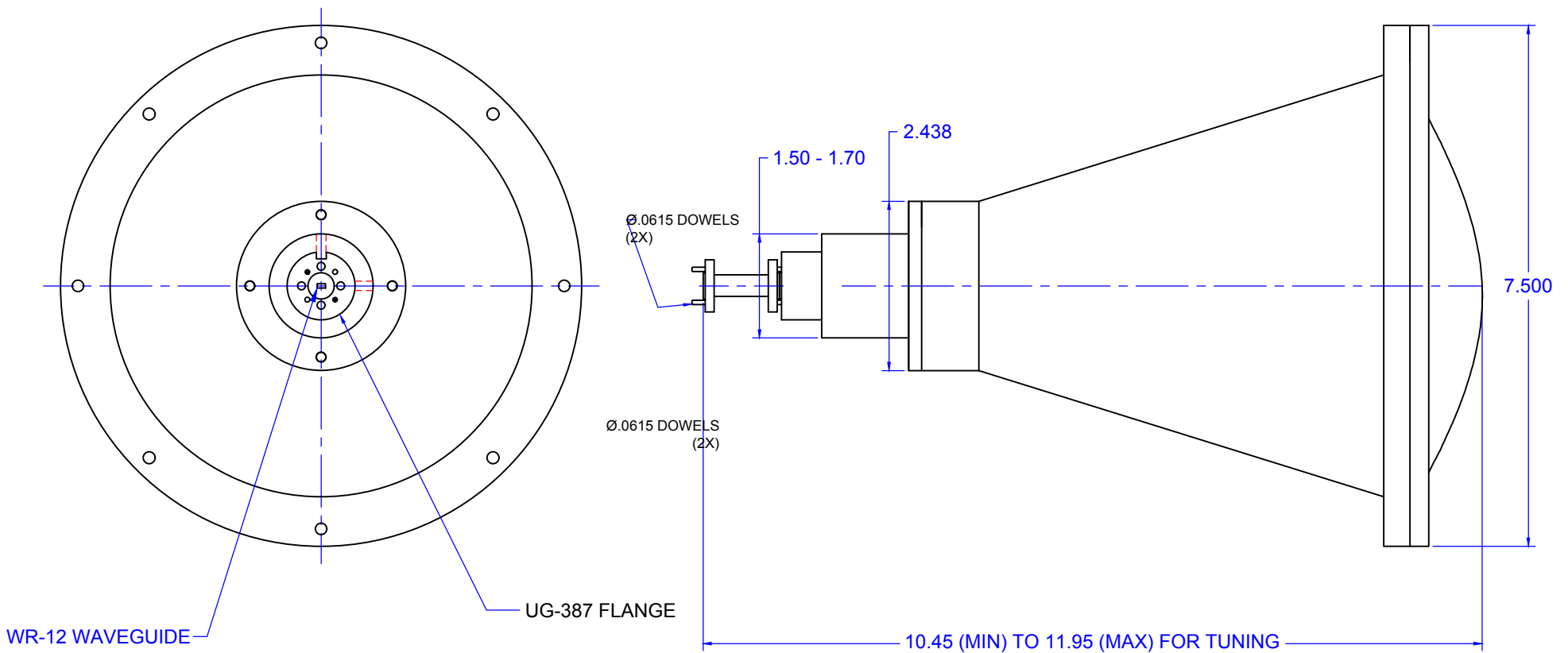

ALL DIMENSIONS ARE
REFERENCE ONLY

UNLESS OTHERWISE SPECIFIED ALL SURFACES $\sqrt{32}$		 THIRD ANGLE PROJECTION		Mi-Wave Millimeter Products Inc.	
DIMENSIONS ARE IN INCHES TOLERANCES ARE: DECIMALS: .1234 +/- .0005 .123 +/- .005 .12 +/- .01 ANGLES: +/- .5 DEGREES		DRAFTING: J. VOLZ		TITLE	
ALL THREADS TO BE 2A OR 2B		APPROVED: M.S.		258E-6-77/387 OUTLINE	
REF DWG# --		DATE: 8-23-18		SIZE	DWG NO
ORIGINAL DWG# 20108e		SHEET NO.	OF	A	24223
		1	1		