

REVISIONS			
REV	DESCRIPTION	DATE	APPROVED
--	--	--	--

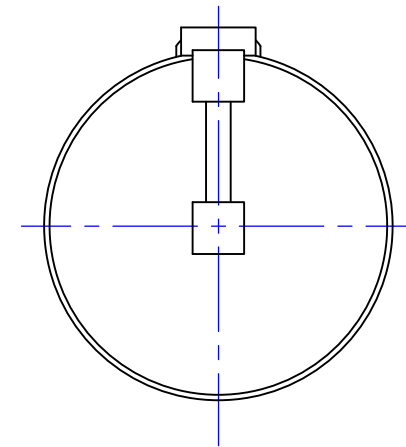

ø3.100

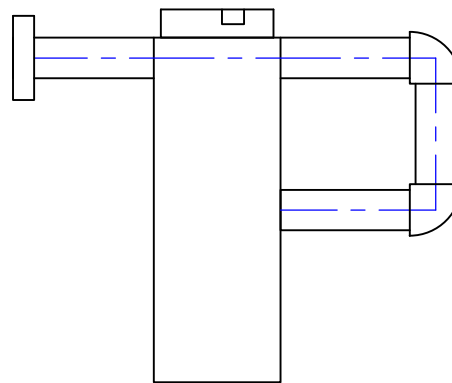
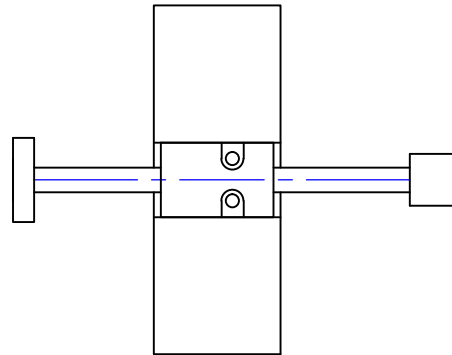
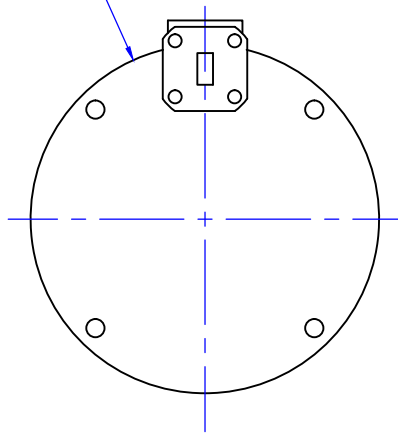

QTY	PART NUMBER	DESCRIPTION		ITEM
UNLESS OTHERWISE SPECIFIED ALL SURFACES $\sqrt{32}$		 THIRD ANGLE PROJECTION		<b>Mi-Wave</b> Millimeter Products Inc.  TITLE <b>202A-3/599</b> <b>PRIME FOCUS ANTENNA</b> <b>FINAL ASSEMBLY</b>
DIMENSIONS ARE IN INCHES TOLERANCES ARE: DECIMALS: .1234 +/- .0005 .123 +/- .005 .12 +/- .01 ANGLES: +/- .5 DEGREES				
ALL THREADS TO BE 2A OR 2B		SHEET NO.	OF	SIZE
REF DWG# --		1	1	A
				DWG NO <b>25136</b>