

Appendix B

Contact Flanges

Finished Flange and Waveguide

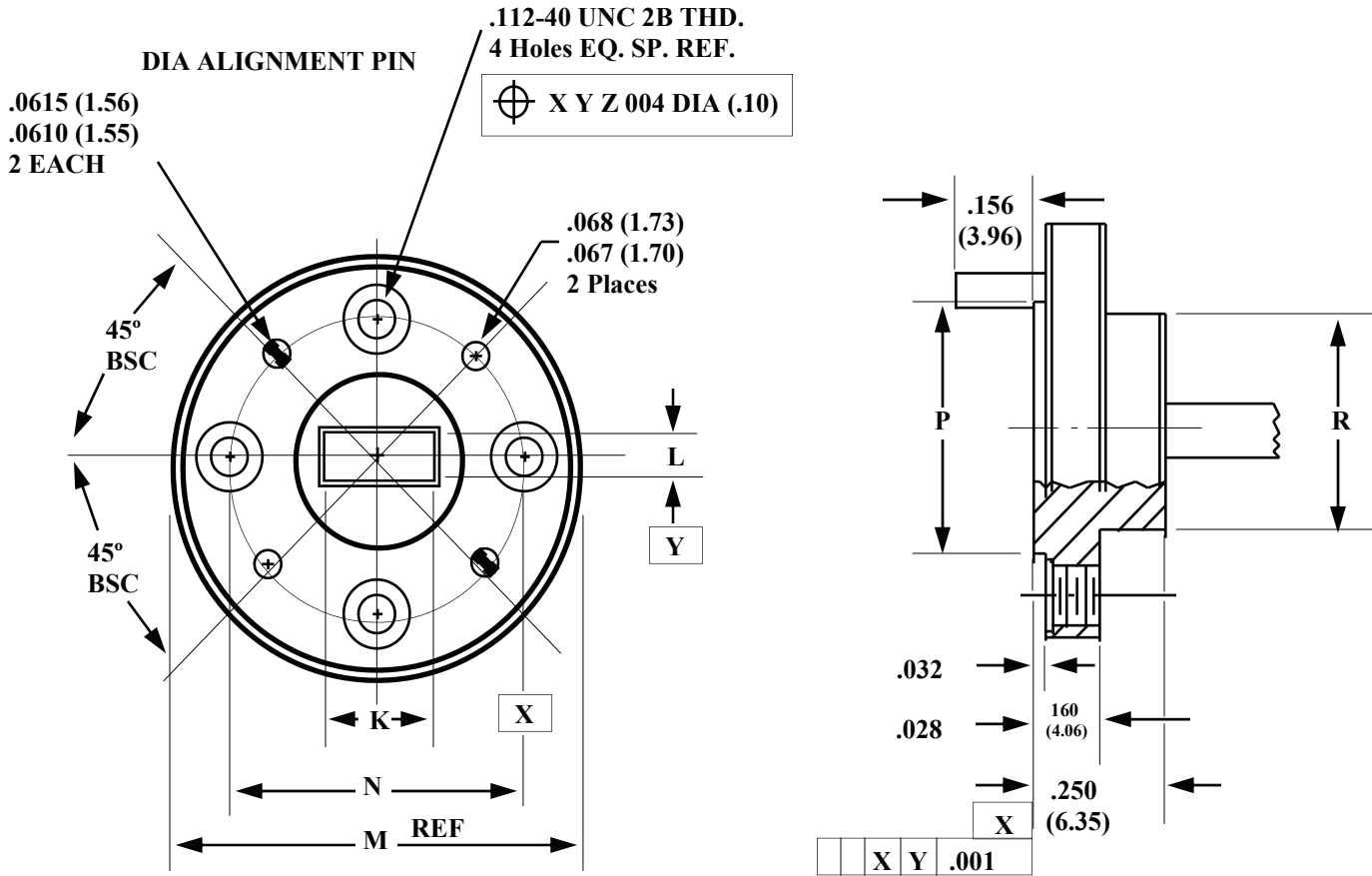

<i>miwv</i> Band	Frequency Band (GHz)	MIL Part Number M3922/67	K ± .0015 (.04)	L ± .0015 (.04)	M ± .000/.002 (.05)	N BSC	P ± .005 (.13)	R ± .005 (.13)	EIA Waveguide Designatio	<i>miwv</i> Flange Designation	<i>miwv</i> Flange Bank
K	18.0 26.5	-004	.4200 (10.67)	.1700 (4.32)	1.125 (28.58)	.9375 (23.81)	.625 (15.88)	.625 (15.88)	WR-42	UG-425/U	101957-10
A	26.5 40.0	-005	.2800 (7.11)	.1400 (3.56)	1.125 (28.58)	.9375 (23.81)	.500 (12.70)	.468 (11.89)	WR-28	UG-381/U	101957-1
B	33.0 50.0	-006	.2240 (5.69)	.1120 (2.84)	1.125 (28.58)	.9375 (23.81)	.500 (12.70)	.468 (11.89)	WR-22	UG-383/U	101957-2
U	40.0 60.0	-007	.1880 (4.78)	.0940 (2.39)	1.125 (28.58)	.9375 (23.81)	.500 (12.70)	.468 (11.89)	WR-19	UG-383/U-M	101957-3
V	50.0 75.0	-008	.1480 (3.76)	.0740 (1.88)	.750 (19.05)	.5625 (14.29)	.375 (9.53)	.312 (7.92)	WR-15	UG-385/U	101957-4
E	60.0 90.0	-009	.1220 (3.10)	.0610 (1.55)	.750 (19.05)	.5625 (14.29)	.375 (9.53)	.312 (7.92)	WR-12	UG-387/U	101957-5
W	75.0 110.0	-010	.1000 (2.54)	.0500 (1.27)	.750 (19.05)	.5625 (14.29)	.375 (9.53)	.312 (7.92)	WR-10	UG-387/U-M	101957-6
F	90.0 140.0	N/A	.0800 (2.03)	.0400 (1.02)	.750 (19.05)	.5625 (14.29)	.375 (9.53)	.312 (7.92)	WR-8	UG-387/U-M	101957-7
D	110.0 170.0	N/A	.0650 (1.65)	.0325 (.83)	.750 (19.05)	.5625 (14.29)	.375 (9.53)	.312 (7.92)	WR-7	UG-387/U-M	101957-8
G	140.0 220.0	N/A	.0510 (1.30)	.0255 (.65)	.750 (19.05)	.5625 (14.29)	.375 (9.53)	.312 (7.92)	WR-5	UG-387/U-M	101957-9